

MANAURITE XM

PHYSICAL PROPERTIES

Specific gravity : 0.29 lb/inch³ (8.02 kg/dm³)
 Melting point : 1350°C (2460°F)

Coefficient of expansion in/in °F (10⁻⁶)

From 70°F to 1560°F : 10.21
 From 70°F to 1740°F : 10.4
 From 70°F to 1920°F : 10.6
 From 70°F to 2100°F : 10.9

mm/mm/°C (10⁻⁶)

20°C to 850°F : 18.5
 20°C to 950°F : 18.9
 20°C to 1050°F : 19.3
 20°C to 1150°F : 19.7

Thermal conductivity

At 1050°C (1922°F) : 30 W/m.°C
 (17 Btu/h.ft.°F)

At 20°C (68°F) : 10.5 W/m.°C
 (6 Btu/h.ft.°F)

Specific heat

Temperature		Cal/g.°C	J/kg.°C
°C	°F	or BTU/lb.°F	
20	68	0.112	469
100	212	0.117	489.9
200	392	0.124	519.3
300	572	0.130	544.4
400	752	0.137	573.7
500	932	0.143	598.8
600	1112	0.150	628.2
700	1292	0.157	657.5
800	1472	0.163	682.6
900	1652	0.170	711.9
1000	1832	0.177	741.2
1100	2012	0.183	766.4
1200	2192	0.190	795.7

Young modulus

Temperature		MPa	ksi
°C	°F		
20	68	161.900	23.470
100	212	155.000	22.475
200	392	147.150	21.337
300	572	138.000	20.010
400	752	133.400	19.343
500	932	126.000	18.270
600	1112	117.700	17.066
700	1292	111.000	16.095
800	1472	106.000	15.360
900	1652	101.000	14.650
1000	1832	97.100	14.080
1100	2012	93.200	13.510

MANAURITE XM

MECHANICAL PROPERTIES

1. At room temperature

(minimum values)

Ultimate tensile strength : 450 Mpa 65 000 psi
Yield strength : 250 Mpa 35 500 psi
Elongation (on 4d) : 8 % for centrifugally cast pipes
6 % for static castings.

2. Short time tensile tests at various temperature on as cast material

Temperature		U.T.S.		Y.S		E
°C	°F	MPa	ksi	MPa	ksi	%
750	1382	333	48.4	157	22.8	16
800	1472	265	38.2	147	21.3	20
850	1562	196	28.4	137	19.9	22
900	1652	147	21.3	118	17.1	30
950	1742	118	17.1	88	12.8	32
1000	1832	93	13.5	78	11.4	38
1050	1922	74	10.7	69	10.0	47
1100	2012	61	8.8	55	8.0	39

(typical values)

MANAURITE XM

3. Long time tests : creep data

Stress rupture properties :
100 000 hours

Temperature		Average values		Minima values	
°C	°F	MPa	ksi	MPa	ksi
800	1470	59,00	8,55	51,00	7,39
825	1515	51,00	7,39	44,63	6,47
850	1560	44,00	6,38	39,00	5,65
875	1605	37,62	5,45	33,01	4,78
900	1652	31,20	4,52	28,00	4,06
925	1697	26,39	3,82	23,00	3,33
950	1742	21,20	3,07	18,70	2,71
975	1787	17,32	2,51	15,00	2,17
1000	1832	13,59	1,97	11,70	1,70
1025	1877	10,40	1,51	9,10	1,32
1050	1922	8,00	1,16	6,80	0,99
1075	1967	6,10	0,88	5,20	0,75
1100	2012	4,60	0,67	3,90	0,57
1125	2057	3,40	0,50	2,90	0,42
1150	2102	2,50	0,36	2,10	0,31
1175	2147	1,75	0,25	1,47	0,21

CREEP RUPTURE DATA - MANAURITE XM

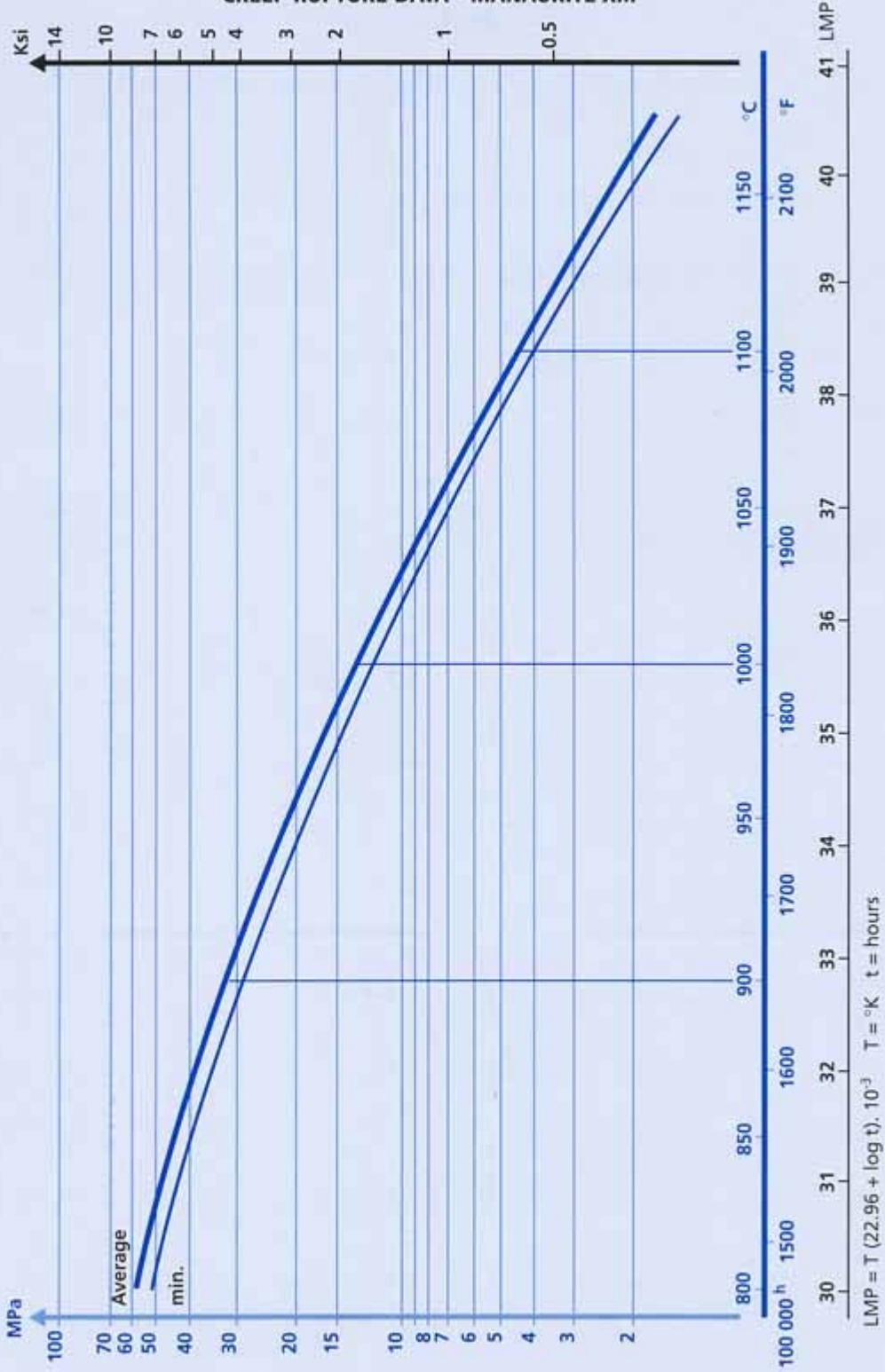

MANAURITE XM

4. Creep data

Creep rates (material stabilized 1050°C - 500 Hrs)

Creep rates (% x hr ⁻¹)	Stresses in MPa		
	950°C 1742°F	1000°C 1832°F	1050°C 1922°F
10 ⁻²	48	35	29
10 ⁻³	34	25	18
10 ⁻⁴	24	18	13.4
10 ⁻⁵	16.8	12	9.4

CREEP RATES MANAURITE XM

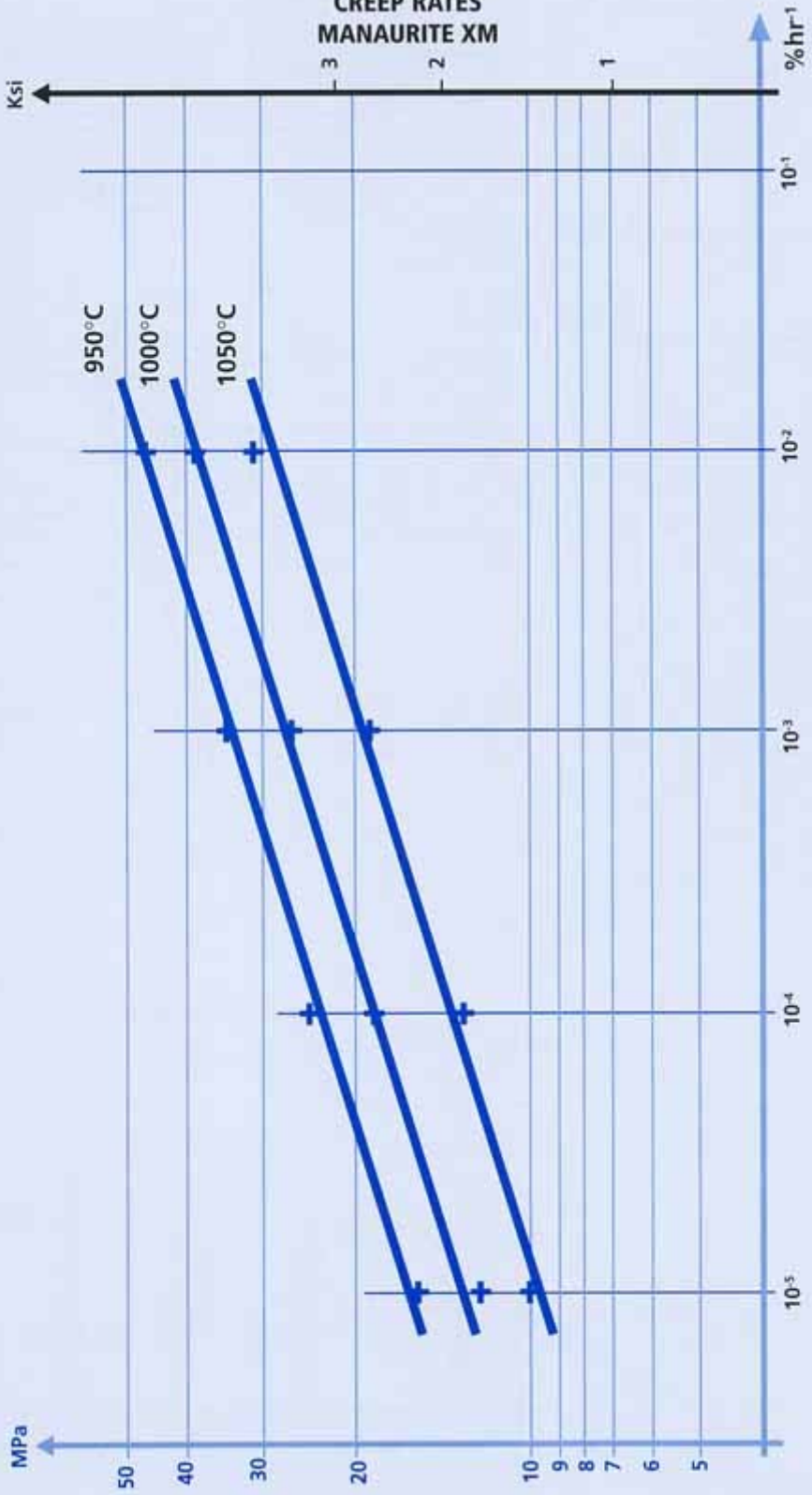

MANAURITE XM

CARBURIZATION RESISTANCE DATA

Pack cement carburization test results
850°C - 1150°C (1562°F - 2102°F) 14 Days

inside (mm)	Minima values	
	%C	Δ C%
0.75	1.98	1.53
1.25	1.23	0.78
1.75	0.83	0.38
2.25	0.62	0.17
2.75	0.51	0.06
2.25	0.45	0.00
3.75	0.45	0.00
4.25	0.45	0.00
4.75	0.45	0.00

Test conditions :
holding for 2 days at each temperature
with an increase of 50°C (122°F) every 2 days from the
minimum temperature to the maximum temperature.

$\Delta C \% = \text{Enrichment in carbon} = \text{total carbon \%} - \text{initial carbon \%}$

CARBURIZATION TEST

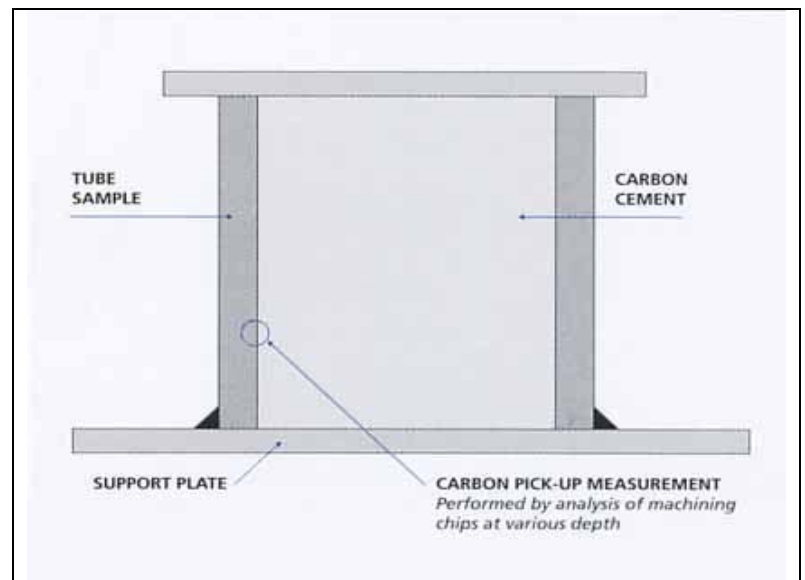

PACK CEMENT CARBURIZATION TEST
MANAURITE XM
(850°C - 1150°C)

